



PEP ecopassport® PROGRAM

PSR

SPECIFIC RULES FOR CABLE MANAGEMENT SOLUTIONS

PSR-0003-ed2-EN-2023 06 06

According to PSR-template-ed2-EN-2021 11 18

©2023 Association P.E.P.

Copyright of PSRs

Product Specific Rules are © PEP ecopassport® program property, if nothing else has been specified (e.g. the cross-publication of PSRs from other programs). The use of the PSRs for any other purpose than to develop and register PEPs in the International PEP ecopassport® program is subject to approval by the General Secretariat, which may be contacted at: contact@pep-ecopassport.org



Contents

1. INTRODUCTION	3
2. SCOPE	4
2.1. DESCRIPTION OF THE PRODUCT FAMILIES COVERED	4
3. PRODUCT LIFE CYCLE ASSESSMENT	6
3.1. COMMON RULES FOR ALL PRODUCT FAMILIES	6
3.2. SPECIFIC RULES FOR THE 'CABLE TRUNKING SYSTEMS AND CONDUIT SYSTEMS' FAMILY	14
3.3. SPECIFIC RULES FOR THE 'CABLE TRAY SYSTEMS AND CABLE LADDER SYSTEMS' FAMILY	18
3.4. SPECIFIC RULES FOR THE 'OTHER CABLE MANAGEMENT PRODUCTS' FAMILY	21
4. DRAWING UP THE PRODUCT ENVIRONMENTAL PROFILE	23
4.1. GENERAL INFORMATION	23
4.2. CONSTITUENT MATERIALS	23
4.3. ADDITIONAL ENVIRONMENTAL INFORMATION	24
4.4. ENVIRONMENTAL DATA REQUIREMENTS	24
4.5. ENVIRONMENTAL IMPACT CALCULATION	25
5. PEP UPDATE RULES	25
6. APPENDICES	26
6.1. APPENDIX 1: CLASSIFICATION OF PRODUCT FAMILIES COVERED BY THIS PSR IN THE PEPecOPASSPORT® DATABASE	26
6.2. APPENDIX 2: DESCRIPTION OF TYPICAL INSTALLATIONS TO DETERMINE BASKETS OF FUNCTIONS	27
6.3. APPENDIX 3: GLOSSARY	31
6.4. APPENDIX 4: DEFINITIONS	31
6.5. APPENDIX 5: REFERENCES	32
6.6. APPENDIX 6: DECLARATION OF CONFORMITY	33

1. Introduction

This reference document complements and explains the Product Environmental Profile (PEP) Drafting Rules defined by the PEP ecopassport® Program (PEP-PCR ed4-EN-2021 09 06), available at www.pep-ecopassport.org.

It defines the additional requirements applicable to cable management solutions. Compliance with these requirements is necessary to:

- Qualify the environmental performance of these solutions on an objective and consistent basis,
- Publish PEPs compliant with the PEP ecopassport® program and international reference standards.¹

This reference document was drawn up in compliance with the open, transparent rules of PEP Ecopassport® Program with the support of manufacturers of cable management solutions.

	www.pep-ecopassport.org
PSR reference	PSR-0003-ed2-EN-2023 06 06
Critical review	The third-party critical review was carried out by SOLINNEN. The declaration of conformity published on 17/04/2023 can be found in Appendices.
Availability	The critical review report is available on request from the PEP Association contact@pep-ecopassport.org
Scope of validity	The critical review report and the declaration of conformity remain valid within 5 years or until the PEP Drafting Rules, or the normative reference texts to which they refer, are modified.

¹ ISO 14025, ISO 14040 and ISO 14044 standards

2. Scope

In accordance with the General Instructions of the PEP ecopassport® program (PEP-General Instructions- ed 4.1-EN-2017 10 17) and additional to the PCR, Product Category Rules (PEP-PCR ed4-EN-2021 09 06) of the PEP ecopassport® environmental product declaration program, this document sets out the specific rules for cable management solutions and defines the product specifications to be adopted by manufacturers in the development of their PRODUCT ENVIRONMENTAL PROFILES (PEPs), particularly with regard to:

- the technology and its type of application,
- the reference service lifetime taken into account for the Life Cycle Assessment (LCA) of products,
- the conventional use scenarios to be adopted during the product use stage.

2.1. Description of the product families covered

This reference document applies to all cable management solutions (lengths and accessories), wherever they are manufactured or whatever their target markets.

These solutions are divided into three separate families, for which particular rules apply to the conducting of Life Cycle Assessments (LCA) and the publication of PEP.

2.1.1. Trunking systems and conduit systems

The 'Trunking Systems & Conduit Systems' product family is defined by:

Product family	Trunking Systems & Conduit Systems
Main function	Lengths and accessories intended to accommodate and protect cables
Relevant standards groups and standards	<ul style="list-style-type: none">• Installation cable trunking systems²: EN 50085-1 and EN 50085-2-1 standards• Distribution cable trunking systems³: EN 50085-1 and EN 50085-2-1 standards• Conduit systems for cable: EN 61386 standards<ul style="list-style-type: none">- Rigid conduit systems: EN 61386-1 and EN 61386-21 standards:- Pliable conduit systems: EN 61386-1 and EN 61386-22 standards:- Buried underground conduit systems: EN 61386-1 standards and associated parts• Floor cable trunking systems: EN 50085-1 and EN 50085-2-2 standards• Slotted cable trunking systems for cabinets: EN 50085-1 and EN 50085-2-3 standards <p>Note: The EN 50085 standard series will be replaced in the future by the EN IEC 61084 series</p>

² Including mini-trunking and skirting

³ Including trunking on cantilever brackets

2.1.2. Cable tray systems and cable ladder systems

The 'Cable Tray Systems & Cable Ladder Systems' product family is defined by:

Product family	Cable tray systems and cable ladder systems
Main function	Lengths and components intended to support and guide cables
Relevant standards groups and standards	<ul style="list-style-type: none">• Cable tray systems: EN 61537 standard• Cable ladder systems: EN 61537 standard

2.1.3. Other cable management products

The 'Other Cable Management Products' product family is defined by:

Product family	Other cable management products
Main function	Other products performing various functions (electrical distribution, protecting and guiding cables, etc.).
Relevant standards groups and standards	<ul style="list-style-type: none">• Home entry technical trunking: EN 50085-1 and EN 50085-2-1 standards• Floor boxes: EN 50085-1, EN 50085-2-2 and EN 60670-23 standards• Service poles and service posts: EN 50085-1 and EN 50085-2-4 standards• Articulated and flexible cable guide systems: EN 62549 standard• Electrical installation mounting systems: EN 62275 + IEC 61914 + IEC 62275 standard <p>Note: The EN 50085 standard series will be replaced in the future by the EN IEC 61084 series</p>

3. Product Life Cycle Assessment

3.1. Common rules for all product families

3.1.1. Functional Unit and reference flow description

3.1.1.1. Functional unit

Not applicable, see specific rules for each product family.

3.1.1.2. Reference product and reference flow description

The reference flow of cable management solutions⁴ shall include the following, at least:

- Cable Management Solution
- The basic packaging of the various lengths and components of the examined reference system, as well as the associated labels and instruction leaflets,
- Only when delivered and/or prescribed with the cable management solutions in the instruction manual, the assembly elements required to join the components of the system (e.g. screws required to secure the profile on the cantilever bracket), and earthing terminals where relevant (e.g. metal cable management systems),
- Only when delivered and/or prescribed with the cable management solutions in the instruction manual, devices used to fix the equipment on a frame (see EN 61537, definitions in Sections 3.20 and 3.21 'external mounting device', such as screws, dowels, or adhesives required to secure cantilever bracket to the frame),
- Where applicable, the scraps related to the installation of the products and specified below.

The equipotential and earthing cables (for metallic cable management systems) are considered outside the field of application of this PSR, because they are not supplied by the manufacturers and are covered by the 'WIRES, CABLES AND ACCESSORIES' PSR. They are taken into account during the equipotential and earthing study.

The manufacturer selects the reference product within its range to be analysed. The PSR sets no requirements.

In the field of cable management solutions, system obsolescence cycles are strongly dependent on the type of building in which they are installed, the quality of their installation, and their conditions of maintenance and use.

Based on feedback from manufacturers in the sector and installation professionals, the Reference Service Life of cable management solutions is 20 years⁵.

This section is supplemented by the rules specific to each product family.

Elements that are not delivered and/or prescribed (assembly and fastening devices) shall be considered in respect of the building.

⁴ The reference flow lists the elements to be counted in the LCA to fulfil the function expressed by the functional unit

⁵ This life time is not related to the duration of the product guarantee or the actual life time of the installation, but it is representative of the life time of a cable management system in the installation or the device being analysed.

3.1.2. System boundaries

These specific rules are additional to Section 2.2 'System Boundaries' of the PCR in force (PEP-PCR ed4-EN-2021 09 06) which describes the boundaries for each stage of the life cycle.

As described in PEP-PCR ed4-EN-2021 09 06, the following stages shall be included:

- Manufacturing stage: the rules described in Section 2.2.3 of PEP-PCR-ed4-EN-2021 09 06 apply
- Distribution stage: the rules described in Section 2.2.4 of PEP-PCR-ed4-EN-2021 09 06 apply
- Installation stage: the rules described in Section 2.2.5 of PEP-PCR ed4-EN-2021 09 06 apply
- Use stage: the rules described in Section 2.2.6 of PEP-PCR ed4-EN-2021 09 06 apply.

In the case of breakdown of module B as defined in Section 2.2.6 of the PCR ed.4, the environmental impacts of the use stage must be broken down as follows for all PSR-0003 product families:

B1: Use or application of the product installed	The specific rules of this PSR do not define elements to be declared in B1.
B2: Maintenance	The specific rules of this PSR do not define elements to be declared in B2.
B3: Repair	The specific rules of this PSR do not define elements to be declared in B3.
B4: Replacement	The specific rules of this PSR do not define elements to be declared in B4.
B5: Restoration	The specific rules of this PSR do not define elements to be declared in B5.
B6: Energy requirements during the use stage	Electricity consumption of the reference product by applying the use scenario as defined by PSR-0003. Module equal to 0 for the ' Conduit Systems and Trunking Systems '; ' Cable Tray Systems and Cable Ladder Systems ' and ' Electrical Installation Mounting Systems ' product families
B7: Water requirements during the use stage	The specific rules of this PSR do not define elements to be declared in B7.

- End-of-life stage: the rules described in Section 2.2.7 of PEP-PCR ed4-EN-2021 09 06 apply.

In the case of breakdown of module C, the environmental impacts of the use stage shall be broken down as following:

C1: Deinstallation
C2: Transport to waste treatment site
C3: Treatment of waste in view of its reuse, recovery and/or recycling
C4: Disposal

- Benefits and loads beyond the system boundaries: the rules described in Section 2.2.8 of PEP-PCR ed4-EN-2021 09 06 apply.

3.1.3. Cut-off criteria

The rules defined in Section 2.3 'Cut-off criteria' of the PCR (PEP-PCR ed4-EN-2021 09 06) apply.

3.1.4. Rules for allocation between co-products

These specific rules are additional to Section 2.4 'Rules for allocation between co-products' of the PCR in force (PEP-PCR ed4-EN-2021 09 06).

In the event of primary data being shared with other products than those concerned by these specific rules, the impacts may be calculated in proportion to the mass of the devices manufactured. Any other rule must be justified in the LCA report and mentioned in the PEP.

3.1.5. Development of scenarios (default scenarios)

These specific rules are additional to Section 2.5 'Development of scenarios (default scenarios)' of the PCR in force (PEP-PCR ed4-EN 2021 09 06).

3.1.5.1. Manufacturing stage

Recycled content

The recycled content of raw materials shall be justified*. In the absence of justified specific information, the recycled content of the constituent materials of the product shall be considered to be nil.

Packaging of raw materials and components

The packaging of raw materials and components as well as their transport to the manufacturing site(s) shall be considered. Supplier data shall be used.

Failing justification, an average packaging content of 5% of the mass of the reference equipment (equipment + packaging) shall be considered, broken down as follows:

- Wood 50%
- Cardboard 40%
- Low-density polyethylene 10%

Packaging reused on-site is not considered.

The end-of-life treatment of packaging is modelled as described below, in the manufacturing waste treatment section of this PSR.

Scrap rate

Specific scrap rates shall be justified*. Declarants whose scrap rates are not available shall consider the default values presented in the first column of Table 1. Columns two and three of the table give an example of how the rates shall be applied.

	Default scrap rate	Mass of part after manufacture	Mass to be considered with scraps
Metals			
Machining	60 %	19.2 kg	48.0 kg
Sheet metal cutting	20 %	14.4 kg	18.0 kg
Coiling	10 %	2.0 kg	1.8 kg
Injection	10 %	0.9 kg	1.0 kg
Moulding	10 %	12.6 kg	14.0 kg
Plastics			
Injection	10 %	9.9 kg	11.0 kg
Packaging	10 %	5 kg	5.5 kg
Other processes	30 %	24.5 kg	35.0 kg

Table 1: Default scrap rate to be considered

Manufacturing waste treatment

By sector-based convention, the transport stage of this manufacturing waste shall be considered based on an assumption of 100 km transport by truck.

In the absence of justified* specific data on the treatment of its manufacturing waste, the declarant shall apply the following default scenario: 100% incineration with no energy recovery.

***Accepted supporting documents to amend default scenarios**

If the declarant wishes to use specific data, the data shall be justified in the report. Such data, forwarded by manufacturers, is not necessarily certified but based on supporting documents on the traceability chain. These supporting documents involve the liability of the declarant or supplier or third party (example of third party: independent certification body). These supporting documents shall be available if requested.

The recycled content of raw materials may for example be justified with supplier data (data sheet or supplier declaration), but may not be justified with generic data (e.g.: system, professional associations, ADEME). The method for calculating the recycled content may be based on that proposed by the EN 45557 standard providing a general method for evaluating the recycled material content of energy-related products.

The scrap rates of raw materials may for example be justified with an internal document from the production factory (e.g.: annual report mentioning the input and output material quantity of the process)

The end-of-life waste treatment may for example be justified with a statement from the contractor tasked with the treatment of waste from the factory.

3.1.5.2. Distribution stage

The rules defined in Section 2.5 'Development of scenarios (default scenarios)' of the PCR (PEP-PCR ed4-EN-2021 09 06) apply.

3.1.5.3. Installation stage

3.1.5.3.1. End of life of packaging

The end of life of packaging, the production of which is included in the manufacturing stage, is included in the installation stage. Packaging waste produced during the installation stage falls within the category of non-hazardous waste and is disposed of, in principle, by the installer once the equipment is installed.

In the absence of supporting documents showing a specific end of life, the treatment scenarios presented in the table below shall be applied by default. The tables presented below are representative of the year 2019. The latest consolidated Eurostat data, if available, may be accessed using the information available at the address: https://ec.europa.eu/eurostat/databrowser/view/ENV_WASPAC__custom_3801295/default/bar?lang=en. The reference year of the data used shall be mentioned in the PEP.

For all geographic scopes:

- By sector-based convention, the transport stage of this manufacturing waste shall be considered based on an assumption of **100 km transport by truck**.
- The strapping, packaging notes and labels present on or in the packaging of the system are considered to be negligible and may be excluded from the life cycle assessment of the packaging waste.
- A pallet may be considered to be suitable for reuse up to 28 times⁶.

For France scope:

	Recycling rate	Incineration with energy recovery	Incineration with no energy recovery	Landfill rate
Metal	83	1	0	16
Steel	88	0	0	12
Aluminium	60	7	0	33
Paper-cardboard	91	5	0	4
Wood	7	31	0	62
Plastic	27	43	0	30

Table 2: default packaging end-of-life for France scope

For European scope:

	Recycling rate	Incineration with energy recovery	Incineration with no energy recovery	Landfill rate
Metal	77	2	0	21
Paper-cardboard	82	9	0	9
Wood	31	31	0	38
Plastic	41	37	0	23

Table 3: default packaging end-of-life for European scope

⁶ Sources: <https://epalia.fr/blog/conseils-dexperts/reemploi-recyclage-valorisation-de-palettes-bois>

In the absence of data in Tables 2 and 3, waste shall be treated according to the following scenario: **100% incineration with no energy recovery.**

For another international geographic scope (excluding France or Europe): waste shall be treated according to the following scenario: **100% incineration with no energy recovery.**

3.1.5.3.2. Installed product scrap

As per PEP-PCR ed4-EN 2021 09 06, product scrap generated during installation (production, transport and end of life) shall be included in the product installation stage (module A5). In the reference flow of this PSR, a specific installed product scrap percentage for each product type is mentioned: production, transport and end of life associated with this installed product scrap shall be modelled and incorporated in module A5.

3.1.5.4. Use stage

3.1.5.4.1. Taking into account product energy consumption

These requirements only concern the “other cable management solutions” (family 3). They supplement and specify the Product Environmental Profile (PEP) Drafting Rules defined by the PEP ecopassport® Program (PEP-PCR ed4-EN-2021 09 06), in the 'Use Stage' and 'Reference product use scenario' sections.

Although the energy consumption and losses via the Joule effect caused by “Other equipped cable management products” (family 3) are relatively small, they must be taken into account in the assessment of the environmental impact of the product.

'Other equipped cable management products' are considered as 'passive products in non-continuous operation'⁷.

In accordance with the Product Environmental Profile (PEP) Drafting Rules defined by the PEP ecopassport® Program (PEP-PCR ed4-EN2021 09 06), their use scenario considers the following:

- 30% of the rated current (I_n) flowing 30% of the time
- For a Reference Service Life of 20 years.

The calculation of this consumption must be documented in the LCA report. The calculation is made by actual measurement of product impedance as follows:

- For each independently-powered circuit, measure the impedance at each power socket outlet, and take the maximum impedance value.
- Impedance is measured using a shunt to close off the circuit at the power socket outlet in order to measure the internal impedance of the circuit at the other end (terminal block, cable, or cord). This measurement is taken with a current higher than or equal to 1 A.
- Apply the following formula:

$$P = (Z_{\text{circuit}1} \times (30\% I_1)^2) + (Z_{\text{circuit}2} \times (30\% I_2)^2) + (Z_{\dots})$$

where $Z_{\text{circuit} n}$ is the maximum impedance of circuit n

⁷ Intended to allow comparison of PEPs, this default scenario is deliberately penalising and represents the use of electrical products through which the main current passes during non-continuous operation. In fact, power outlets are not always used at rated current and, when they are, this occurs intermittently, depending on the habits of the users.

Note:

- The energy consumption of the active elements incorporated in the cable management products must be added to the calculation of energy dissipation by the Joule effect of the energy network (e.g. indicator light, circuit breaker, surge arrester, etc.)
- The energy losses due to the Voice Data Image (VDI) elements of the cable management products, only operating in digital data transmission mode (i.e. without transmission of a power supply current to the connected devices, e.g.: PoE Power on Ethernet), were determined to be negligible in comparison with elements of the energy network (*). This consumption should not be taken into account in the Life Cycle Assessments (LCA). It will be mentioned in the LCA report.
- Laboratory test reports shall be provided to justify the impedance measurements.

(*) As an example, the energy dissipation of a standard RJ45 socket installed in a communication network in a typical commercial office and used only for Ethernet according to the 802.3-2002 standard, is less than 0.02 mW, which corresponds to dissipated energy lower than 0.7 Wh over 20 years at the rate of 8 hours of use per day, 220 days per year. These consumption values do not change the LCA results for the cable management solutions.

3.1.5.4.2. Taking into account energy consumption

The manufacturer shall use the following formula to calculate product energy consumption:

$$(P \text{ diffused by Joule effect} + P \text{ of active elements}) \times (20 \text{ years} \times 30\%)$$

3.1.5.4.3. Maintenance

The rules defined in Section 2.5.5 'Maintenance scenarios' of the PCR (PEP-PCR ed4-EN-2021 09 06) apply. No maintenance rules need to be defined for the product categories covered by this PSR.

3.1.5.5. End of life cycle stage

By sector-based convention, the end-of-life collection transport stage shall be considered based on an assumption of 100 km transport by truck.

Given the life time of these products, no specific data can be used by the declarant to model the end of life of its product, regardless of the geographic representativeness of the study. The declarant shall apply the following default scenario: 100% incineration with no energy recovery.

3.1.5.6. Scenario for considering net benefits and loads beyond the system boundaries

The rules defined in Section 2.5.7 'Scenario for considering net benefits and loads beyond the system boundaries' of the PCR (PEP-PCR ed4-EN-2021 09 06) apply.

3.1.6. Rule(s) for extrapolation to a homogeneous environmental family

These specific rules are additional to Section 2.6 'Rule(s) for extrapolation to a homogeneous environmental family' of the PCR in force (PEP-PCR ed4-EN-2021 09 06).

The extrapolation coefficients apply to '**Conduit systems and trunking systems**', '**Cable tray systems and cable ladder systems**' and to '**Electrical installation mounting systems**'

They enable users to use the environmental data provided in the PEP for cable management systems other than the reference system for which the PEP was calculated.

To date, on account of the great technical disparity of the '**Other cable management products**' family, with the exception of '**Electrical installation mounting systems**', no universal extrapolation rule has been defined. The use of extrapolation rules for the 'Other Cable Management Products' family shall be justified in accordance with PCR-4-ed4-EN-2021 09 06.

The PEP shall mention the extrapolation coefficients to be applied to the indicators at each stage or to the total life cycle.

After a documented sensitivity study, it has been proven that the environmental impacts of these systems on A1 to C4 stages are globally proportional to their mass. An extrapolation methodology applicable to all life cycle stages (A1-C4) has been established and presented in table 4 below.

The parameters that impact the module D are:

- The quantity of recycled content in the raw material used to manufacture the products,
- The quantity of losses and waste generated throughout all life cycle and their treatment.

These parameters are directly related to the product mass and are not supposed to vary within the same homogeneous environmental family (in accordance with paragraph 2.6 of PCR-ed-EN-2021 09 06: Similar manufacturing technology: same type of materials and manufacturing processes).

Thus extrapolation rule based on product mass can also apply to module D.

3.1.6.1. Methodological and writing requirements to extrapolate the LCA results from the reference system

These requirements are applicable to 'Conduit Systems and Trunking Systems', 'Cable Tray Systems and Cable Ladder Systems' and to 'Electrical Installation Mounting Systems':

Methodological & writing requirements	Illustration provided for information
1. Take as base 100, the mass of the reference system used for the LCA whose results are given in the PEP ecopassport®.	Example for a mass of the reference system: 'XL mini-trunking' The system whose section is 32 x 12.5 has a mass of 3.9 kg.
2. Fill in the total system mass for a different section (mass of System A) belonging to the same reference family or homogeneous environmental family.	Mass of System A 'XXL mini-trunking' The system whose section is 40 x 12.5 with partition has a mass of 4.81 kg
3. Calculate the following coefficient: Mass of System A/Mass of reference system = extrapolation coefficient to be applied to environmental indicator values	In this example, the extrapolation coefficient is: 4.81 kg / 3.9 kg = 1.23
4. Create and fill in a table to be included in the 'Environmental impacts' section of the PEP ecopassport® with the note opposite.	<u>Note</u> <i>'The environmental impact of a system covered by the PEP ecopassport® other than the reference system for which it was drawn up can be calculated by multiplying the values of the environmental indicators by the corresponding factor for each stage of the life cycle and the total life cycle'</i>

Depth (mm)	25	25	40	40	40	40	40	60	60	60
Width (mm)	25	40	25	40	60	80	100	25	40	60
Coefficient	0.4	0.5	0.5	0.7	1.0	1.2	1.8	0.6	0.9	1.2

Table 4: Sample conversion table provided for information

3.1.7. Rules applying to joint environmental declarations

The rules defined in Section 2.7 'Rules applying to joint environmental declarations' of the PCR (PEP-PCR ed4-EN-2021 09 06) apply.

The PEP must specify the framework of validity of the application of extrapolation rules based on technical criteria used to check that the products belong to the same homogeneous environmental family as the standard product.

3.1.8. Environmental data requirements

The rules defined in Section 2.9 'Environmental data requirements' of the PCR (PEP-PCR ed4-EN-2021 09 06) apply.

3.1.9. Environmental impact calculation

The rules defined in section 2.10 'Environmental impact calculation' of the PCR (PEP-PCR ed4-EN-2021 09 06) apply.

3.2. Specific rules for the 'Cable trunking systems and conduit systems' family

3.2.1. Functional Unit and reference flow description

These specific rules are additional to Section 2.1 'Functional unit and reference flow description' of the PCR in force (PEP-PCR ed4-EN-2021 09 06).

3.2.1.1. Functional unit

The function of these systems is to accommodate and protect cables for energy and communication systems. This function is determined by the enclosed volume of the profile and is therefore directly related to the usable cross-section for cables.

The functional unit (FU) of installation cable trunking or mini-trunking and skirting systems must be expressed in terms of length measurements.⁸

The functional unit and the technical specifications of the table below shall be presented:

⁸ The ISO 14040 standard defines the functional unit (FU) as the 'quantified performance of a system of products for use as a reference unit in a life cycle assessment'. For cable management products, the service performed to be quantified is associated with the wiring (e.g. Usable cross sectional of cables to be accommodated, weight of cables to be supported, etc.).

3.2.1.1.1. Installation cable trunking or mini-trunking and skirting systems

Family	Cable trunking systems and conduit systems
Sub-family (if required)	Installation cable trunking or mini-trunking and skirting systems
Functional unit	'Accommodate and protect the wiring and wiring accessories along 1 metre for a Reference Service Life of the product of 20 years.' The X system with cross-section Y mm ² includes the profile and accessories that are representative of standard use.
Specifications	X = 'Installation trunking' or 'Mini-trunking and skirting' Y = Usable cross sectional for wiring in the enclosed volume of the profile

3.2.1.1.2. Distribution cable trunking systems, floor trunking systems and conduit systems

Family	Cable trunking systems and conduit systems
Sub-family (if required)	Cable trunking systems, floor trunking systems and conduit systems
Functional unit	'Accommodate and protect the wiring along 1 metre for a Reference Service Life of the product of 20 years.' The X system with cross-section Y mm ² includes the profile and accessories that are representative of standard use.
Specifications	X = 'Distribution trunking' or 'Trunking for distribution on cantilever brackets' or 'floor trunking' or 'Rigid conduit' or 'Surface-mounted or embedded flexible conduits' or 'Buried underground conduit' Y = Usable cross sectional for wiring in the enclosed volume of the profile

3.2.1.1.3. Slotted cable trunking systems for cabinets

The Functional Unit of slotted cable trunking systems for cabinets shall be expressed in length measurements and shall be written as follows:

Family	Cable trunking systems and conduit systems
Sub-family (if required)	Slotted cable trunking systems for cabinets
Functional unit	Accommodate and protect the wiring along 1 meter for a Reference Service Life of 20 years. Slotted cable trunking systems for cabinets with cross-section Y mm ² include the profile (base and cover) representative of standard use.
Specifications	Y = Usable cross-section for wiring in the enclosed volume of the profile

3.2.1.2. Reference product and reference flow description

To determine the reference flow, the manufacturer must apply the basket of functions corresponding to the analysed system. It identifies and lists the commercial catalogue numbers (lengths and components) that will fulfil the specified functions in both quantity and diversity.

These baskets of functions have been established by agreement and documented by all IGNES manufacturers to allow comparison of PEPs. The functions fulfil the requirements of the typical installations representing standard uses observed in the intended markets (refer to the Detail and justification of baskets of functions in Appendix 2).

No alternatives are accepted in cases of innovations in relation to the baskets of functions described in this PSR. In this case, a PSR update will be required.

3.2.1.2.1. Installation Cable Trunking or Mini-Trunking and Skirting Systems

The reference flow of installation trunking systems must fulfil the functions defined in the following baskets:

Basket of functions N°1 'Installation trunking systems'	
Functions to be fulfilled	Total normalized to meters installed
1 m length + 3% scrap rate	1.03*
90° angle with plane change	0.10
90° angle in the plane	0.10
90° diversion in the plane	0.00
Junction	0.29
Termination of trunking	0.19
Single apparatus mounting	0.19
Double apparatus mounting	0.19

* 1.03 m of profiles taken into account to install 1 m of linear trunking function (manufacture, transport and end of life associated with 3% scrap are to be modelled in A5).

Basket of functions N°2 'Mini-trunking and skirting systems'	
Functions to be fulfilled	Total normalized to meters installed
1 m length + 3% scrap rate	1.03*
90° angle with plane change	0.15
90° angle in the plane	0.20
90° diversion in the plane	0.00
Junction	0.20
Termination of trunking	0.10
Single apparatus mounting	0.15
Double apparatus mounting	0.05

* 1.03 m of profiles taken into account to install 1 m of linear trunking function (manufacture, transport and end of life associated with 3% scrap are to be modelled in A5).

3.2.1.2.2. Distribution trunking systems and conduit systems

Flexible conduits:

The reference flow of Surface-mounted or embedded flexible conduits is defined as 1 m in length with a scrap rate in the installation stage of 3%, i.e. 1.03 metres manufactured per 1 metre installed (the manufacture, transport and end of life associated with 3% scrap are to be modelled in A5).

Other distribution trunking systems:

The reference flows of other distribution trunking systems and conduit systems must fulfil the functions defined in the following baskets:

Basket of functions N°3 'Distribution trunking systems'	
Functions to be fulfilled	Total normalized to meters installed
1 m length + 3% scrap rate	1.03*
90° angle with plane change	0.05
90° angle in the plane	0.05
90° diversion in the plane	0.00
Junction	0.38
Termination of trunking	0.11
Single apparatus mounting	0.00
Double apparatus mounting	0.00

* 1.03 m of profiles taken into account to install 1 m of linear trunking function (manufacture, transport and end of life associated with 3% scrap are to be modelled in A5).

Basket of functions N°4 'Rigid conduit systems'	
Functions to be fulfilled	Total normalized to meters installed
1 m length + 3% scrap rate	1.03*
90° angle with plane change	0.00
90° angle in the plane	0.36
90° diversion in the plane	0.00
Junction	0.00
Termination of trunking	0.00
Single apparatus mounting	0.00
Double apparatus mounting	0.00
Wall mounting element	1.27

* 1.03 m of profiles taken into account to install 1 m of linear trunking function (manufacture, transport and end of life associated with 3% scrap are to be modelled in A5).

Basket of functions N°5 'Trunking for distribution on cantilever brackets'	
Functions to be fulfilled	Total normalized to meters installed
1 m length + 3% scrap rate	1.03*
90° angle with plane change	0.04
90° angle in the plane	0.16
Junction	0.33
Earthing terminal (for a metal trunking and if imposed by national regulations)	0.10
Cantilever bracket (including elements for fixing the length) - span 1.5 m	0.66

* 1.03 m of profiles taken into account to install 1 m of linear trunking function (manufacture, transport and end of life associated with 3% scrap are to be modelled in A5).

3.2.1.2.3. Floor trunking systems

The reference flow of the floor trunking systems must fulfil the functions defined in the following basket (see diagram in Appendix 2):

Basket of functions N° 6 'Floor trunking systems'	
Functions to be fulfilled	Total normalized to meters installed
1 m length + 3% scrap rate	1.03*
90° angle with plane change	0.005
90° angle in the plane	0.016
90° diversion in the plane	0.011
Junction	0.333
Termination of trunking	0.011
Flush-mount box	0.327

* 1.03 m of profiles taken into account to install 1 m of linear trunking function (manufacture, transport and end of life associated with 3% scrap are to be modelled in A5).

3.2.1.2.4. Slotted cable trunking systems for cabinets

The reference flow of slotted cable trunking systems for cabinets is defined as 1 m in length with a scrap rate in the installation stage of 10%, i.e. 1.10 metres manufactured per 1 metre installed (the manufacture, transport and end of life associated with 3% scrap are to be modelled in A5).

3.3. Specific rules for the 'Cable tray systems and cable ladder systems' family

3.3.1. Functional Unit and reference flow description

These specific rules are additional to Section 2.1 'Functional unit and reference flow description' of the PCR in force (PEP-PCR ed4-EN-2021 09 06).

3.3.1.1. Functional unit

The function of these systems is to support and guide cables for energy and communication systems. This function is determined and limited by the capacity to mechanically support the cables.

The functional unit (FU) of cable tray systems and cable ladder systems must be expressed in terms of length measurements.

The functional unit and the technical specifications of the table below shall be presented:

3.3.1.1.1. Cable tray systems

Family	Cable tray systems and cable ladder systems
Sub-family (if required)	Cable tray systems:
Functional unit	'Support the wiring along 1 metre for a Reference Service Life of 20 years.' The cable tray system, capable of supporting a load of Y kg per metre on a span of P m, includes the profile and cable management and support components typical of standard use.
Specifications	Y = Indicate in terms of mass (kg) the information established by the manufacturer for the reference system. Safe Working Load as defined by the EN 61537 standard, Section 3.17 P = Cable tray span: '1.5 m' (cable trays) OR '1 m' (cable trays for photovoltaic applications)

3.3.1.1.2. Cable ladder systems

Family	Cable tray systems and cable ladder systems
Sub-family (if required)	Cable ladder systems:
Functional unit	'Support the wiring along 1 metre for a Reference Service Life of 20 years.' The <u>cable ladder</u> system, capable of supporting a load of Y kg per metre on a span of <u>2 m</u> , includes the profile and cable management and support components typical of standard use.
Specifications	Y = Indicate in terms of mass (kg) the information established by the manufacturer for the reference system. Safe Working Load as defined by the EN 61537 standard, Section 3.17

3.3.1.2. Reference product and reference flow description

To determine the reference flow, the manufacturer must apply the basket of functions corresponding to the analysed system. He identifies and lists the Catalog Numbers of the components (lengths and accessories) that will satisfy the specified functions in both quantity and diversity.

These baskets of functions have been established by agreement and documented by all IGNES manufacturers to allow comparison of PEPs. The functions fulfil the requirements of the typical installations representing standard uses observed in the intended markets (refer to the Detail and justification of baskets of functions in Appendix 2).

3.3.1.2.1. Cable tray systems

The reference flow of cable tray systems must fulfil the following functions:

Basket of functions N°7 Cable tray systems	
Functions to be fulfilled	Total normalized to meters installed
1 m length + 3% scrap rate	1.03*
90° angle with plane change	0.04
90° angle in the plane	0.16
Junction	0.33
Earthing terminal (for a metal cable tray and if imposed by national regulations)	0.10
Cantilever bracket (including elements for fixing the length) - span 1.5 m	0.66

* 1.03 m of profiles taken into account to install 1 m of linear trunking function (manufacture, transport and end of life associated with 3% scrap are to be modelled in A5).

Basket of functions N°8 Cable tray systems for flat roof photovoltaic applications	
Functions to be fulfilled	Total normalized per m installed
Length with cover (in m)	1.00
Scrap rate on length with cover (3%)	0.03*
90° angle in the plane with cover	0.03
90° angle with plane change with cover	0.03
90° diversion in the plane with cover	0.02
Junction	0.33
Termination of trunking	0.03
Frontage support (mounting elements to length included)	0.12
Flat roof support (mounting elements to length included)	1.00
Earthing terminal (for a metal cable tray and if imposed by national regulations)	0.10

* 1.03 m of profiles taken into account to install 1 m of linear trunking function (manufacture, transport and end of life associated with 3% scrap are to be modelled in A5).

3.3.1.2.2. Cable ladder systems

The reference flow of the cable ladder systems must satisfy the functions defined in the following basket:

Basket of functions N°9 Cable ladder systems	
Functions to be fulfilled	Total normalized to meters installed
1 m length + 3% scrap rate	1.03*
90° angle with plane change	0.04
90° angle in the plane	0.16
Junction	0.33
Earthing terminal (for a metal cable ladder and if imposed by national regulations)	0.10
Cantilever bracket (including elements for fixing the length) - span 2 m	0.50

* 1.03 m of profiles taken into account to install 1 m of linear trunking function (manufacture, transport and end of life associated with 3% scrap are to be modelled in A5).

3.4. Specific rules for the 'Other Cable Management Products' family

3.4.1. Functional Unit and reference flow description

These specific rules are additional to Section 2.1 'Functional unit and reference flow description' of the PCR in force (PEP-PCR ed4-EN-2021 09 06).

3.4.1.1. Functional unit

The function of these systems is to accommodate and protect cables for energy and communication systems. This function is determined by the enclosed volume of the profile and is therefore directly related to the usable cross-section for cables.

The functional unit (FU) of other cable management products must be expressed in metres. The functional unit and the technical specifications of the table below shall be presented:

3.4.1.1.1. Non-equipped service poles, service posts, multi-outlets extensions and floor boxes

For non-equipped service poles, service posts, multi-outlet extensions and floor boxes, the functional unit of this product family must be written as follows:

Family	NON-EQUIPPED SERVICE POLES, SERVICE POSTS, MULTI-OUTLETS EXTENSIONS AND FLOOR BOXES
Functional unit	'Connect a workstation remote from the wall to the energy and communication networks for 20 years, via X wiring accessories.
Specifications	X = Specify the number and, where appropriate, the type of wiring accessories that the reference product can accommodate (2 x 2P, 4 x 2P + GND, 2 RJ 45 connectors, etc.)

3.4.1.1.2. Pre-equipped service poles, service posts, multi-outlets extensions and floor boxes

For pre-equipped service poles, service posts, multi-outlet extensions and floor boxes, the functional unit of this product family must be written as follows:

Family	SERVICE POLES, SERVICE POSTS, MULTI-OUTLETS EXTENSIONS AND FLOOR BOXES
Functional unit	'Distribute the network(s) Y to the workstation via X wiring accessories for 20 years.'
Specifications	Y = Specify the type of flow: Electrical energy network OR communication network, or energy and communication networks X = Specify the number and type of wiring accessories equipping the reference product (2 x 2P, 4 x 2P + GND, 2 RJ 45 connectors, etc.)

3.4.1.1.3. Home entry technical trunking

For home entry technical trunking, the FU must be written as follows:

Family	HOME ENTRY TECHNICAL TRUNKING
Functional unit	'Accommodate and protect wiring in three compartments* on a X height and allow installation of cabinets for 20 years.'
Specifications	X = Standard trunking height: '2.6 m' (floor-to-ceiling installation) OR '1.5 m' (mid-height installation)

* Home entry technical trunking must accommodate and protect wiring in three compartments (energy supplier + energy distribution + communication) to the intended height.

3.4.1.1.4. Articulated and flexible systems for cable guiding

The Functional Unit for the reference articulated and flexible cable guide systems shall be written as follows:

Family	ARTICULATED AND FLEXIBLE CABLE GUIDE SYSTEMS
Functional unit	'Guide the wiring along the last length to the workstation for 20 years'

3.4.1.1.5. Mounting Systems

The Functional Unit of electrical installation mounting systems shall be expressed in length measurements and shall be written as follows:

Family	ELECTRICAL INSTALLATION MOUNTING SYSTEMS
Functional unit	'Mount a cable or a tube at a point with an X with a clamping capacity between Y and C for a reference lifetime of 20 years'
Specifications	X = Mounting element (collar, tie, loop, etc.) Y = Minimum clamping capacity (unit to be added mm) C = Maximum clamping capacity (unit to be added mm)

3.4.1.2. Reference product and reference flow description

3.4.1.2.1. Home entry technical trunking

To allow comparison of PEPs and in accordance with the applicable product standards, the following must be taken into account in the reference flows for home entry technical trunking: the trunking body for the intended height of the reference product (1.5 or 2.6 m), all trunking covers for the intended height (if the home entry technical trunking is supplied with several covers. Each cover should be taken into account), all the dividers for partition, the scrap length generated during its installation. This is the difference between the length of trunking sold and the standard height of the typical installation (1.5 m or 2.6 m), an end cap when the home entry technical trunking is intended for a mid-height installation, the other accessories and fasteners if they are supplied or prescribed with the product in the instruction manual (floor / ceiling junction, cable retainer, etc.).

4. Drawing up the Product Environmental Profile

The rules specified in Section 4. 'Drawing up the Product Environmental Profile' of the PCR in force (PEP-PCR ed4-EN-2021 09 06) apply.

4.1. General information

These specific rules are additional to Section 4.1 'General information' of the PCR in force (PEP-PCR ed4-EN-2021 09 06) which describes the boundaries for each stage of the life cycle.

The PEP shall mention:

- The family and sub-family as defined in Section 2.1,
- The function fulfilled by the product,
- The use scenario considered in the use stage according to Section 3.1.5.3,
- For PEPs valid for a different product range or scope, the extrapolation rules.

4.2. Constituent materials

The rules specified in the 'Constituent materials' section of the PCR in force (PEP-PCR ed4-EN-2021 09 06) apply.

4.3. Additional environmental information

These specific rules are additional to the 'Additional environmental information' section of the PCR (PEP- PCR-ed4-EN-2021-09 06).

Within the scope of Life Cycle Assessments in respect of a building, the environmental impacts of the equipment shall be considered in respect to the product and impacts associated with energy consumption in the use stage shall be extracted. In this way, to facilitate PEP use for the building LCA, the PEP may include the environmental impact results in the use stage according to a breakdown of module B (B1 to B7) in line with the EN 15978 and EN 15804 standards.

PEP ecopassport®	Manufacturing stage			Distribution stage	Installation stage	Use stage							End of life cycle stage				Benefits and loads
	Production stage			Construction stage		Use stage							End of life cycle stage				Benefits and loads
EN 15978 / 15804	A1	A2	A3	A4	A5	B1	B2	B3	B4	B5	B6	B7	C1	C2	C3	C4	D
Procurement of raw materials																	
Transport																	
Manufacture																	
Transport																	
Installation processes																	
Use																	
Maintenance																	
Repair																	
Replacement																	
Restoration																	
Energy consumption during building use																	
Water consumption during building use																	
Demolition / Deconstruction																	
Transport																	
Waste treatment																	
Disposal																	
Benefits beyond the system boundaries																	

Note: When the total for module D is negative, this represents a benefit. When the total for module D is positive, this represents a load.

4.4. Environmental data requirements

Note: The LCI module used to model the raw material or component may contain a default scrap rate.

- If the scrap rate included in the LCI module is modifiable, the default values of table 1 shall apply.
- If the scrap rate included in the LCI module is non-modifiable:
 - The scrap rate is less than the default values of table 1: this scrap rate shall be entered in the LCA report, and insofar as possible, the modelling should be adapted to account for the difference in waste generated (hazardous or non-hazardous).
 - The scrap rate is greater than the default values of table 1: this scrap rate must be entered in the LCA report.

4.5. Environmental impact calculation

In order to meet the requirements of the PCR in force (PEP- PCR-ed4-EN-2021-09 06), the results presented in the environmental impact table relate to the implementation of the functional unit.

The environmental database version shall be mentioned in the PEP and the LCA report, including the EF (Environmental Footprint) version number.

If mentioning the quantity of biogenic carbon stored in kg: for biogenic carbon storage, both 0/0 or -1/+1 assessment methodologies are accepted until the environmental databases are updated. The methodologies used shall be mentioned in the PEP and in the LCA report.

5. PEP update rules

The rules defined in Section 5 'PEP update rules' of the PCR in force (PEP-PCR ed4-EN-2021 09 06) apply.

6. Appendices

6.1. Appendix 1: classification of product families covered by this PSR in the PEpecopassport® database

The product families covered by this PSR are:

Product family	Level 1	Level 2	Level 3	Level 4
Installation trunking systems	Installation wiring devices for electric power and communication networks (≤ 63 amperes)	Cables management solution	Trunking systems and conduit systems	Installation cable trunking systems
Distribution trunking systems	Installation wiring devices for electric power and communication networks (≤ 63 amperes)	Cables management solution	Trunking systems and conduit systems	Distribution cable trunking systems
Rigid conduit systems	Installation wiring devices for electric power and communication networks (≤ 63 amperes)	Cables management solution	Trunking systems and conduit systems	Rigid conduit systems
Flexible conduit systems	Installation wiring devices for electric power and communication networks (≤ 63 amperes)	Cables management solution	Trunking systems and conduit systems	A créer Pliable conduit systems
Buried underground conduit systems	Installation wiring devices for electric power and communication networks (≤ 63 amperes)	Cables management solution	Trunking systems and conduit systems	A créer Conduit systems buried underground
Floor trunking systems	Installation wiring devices for electric power and communication networks (≤ 63 amperes)	Cables management solution	Trunking systems and conduit systems	Floor cable trunking systems
Slotted cable trunking systems for cabinets	Installation wiring devices for electric power and communication networks (≤ 63 amperes)	Cables management solution	Trunking systems and conduit systems	Slotted cable trunking systems for cabinets
Cable tray systems	Installation wiring devices for electric power and communication networks (≤ 63 amperes)	Cables management solution	Cable tray system and cable ladder system	Cable tray wire Ou Cable tray slab
Cable ladder systems	Installation wiring devices for electric power and communication networks (≤ 63 amperes)	Cables management solution	Cable tray system and cable ladder system	Cable ladder systems
Home entry technical trunking	Installation wiring devices for electric power and communication networks (≤ 63 amperes)	Cables management solution	Others cable management products	Home entry technical trunking
Floor boxes	Installation wiring devices for electric power and communication networks (≤ 63 amperes)	Cables management solution	Others cable management products	Floor boxes
Service poles and service posts	Installation wiring devices for electric power and communication networks (≤ 63 amperes)	Cables management solution	Others cable management products	Service poles and service posts
Articulated and flexible cable guide systems	Installation wiring devices for electric power and communication networks (≤ 63 amperes)	Cables management solution	Others cable management products	Others and accessories
Electrical installation mounting systems	Installation wiring devices for electric power and communication networks (≤ 63 amperes)	Cables management solution	Others cable management products	Others and accessories

6.2. Appendix 2: Description of typical installations to determine baskets of functions

To determine the reference flow, the manufacturer must apply the basket of functions corresponding to the analysed system. He identifies and lists the Catalog Numbers of the components (lengths and accessories) that will satisfy the specified functions in both quantity and diversity.

In order to allow comparison of PEP, these baskets of functions have been established by agreement and documented by all manufacturers involved in the process, who represent more than 95% of the activities in their trade in terms of business volume. The functions satisfy the requirements of the typical installations representative of standard use seen in the various intended markets.

Each typical installation representative of these standard uses has a corresponding basket of functions illustrated by a simple diagram, whose details are given below:

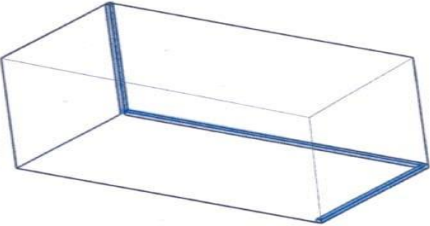
TYPICAL INSTALLATION NO.1 Installation trunking systems	Basket of functions N°1 Installation trunking systems		Total normalized to installed m
Room with a vertical drop (of 2.5 m) + 2 equipped wall sections (2x4m)	Functions to be fulfilled	Number of functions	
	Length (m)	10.50	
	Length scrap rate (3%)	0.32	1.03 m *
	90° angle with plane change	1	0.10
	90° angle in the plane	1	0.10
	90° diversion in the plane	0	0.00
	Junction	3	0.29
	Termination of trunking	2	0.19
	Single apparatus mounting	2	0.19
Double apparatus mounting	2	0.19	
* = 1.03 m of profiles taken into account to install 1 m of linear trunking function			

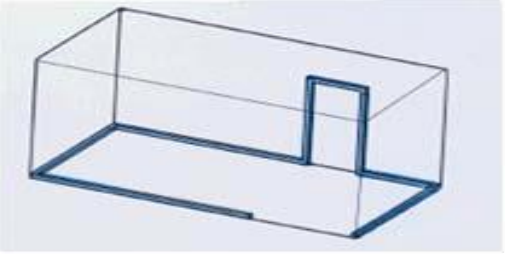
TYPICAL INSTALLATION NO.2 Mini-trunking & skirting systems	Basket of functions No.2 Mini-trunking & skirting systems		Total normalized to installed
16m ² room with 4 wall sections to be covered (4x4m) + 1 door frame (2x2m) with interruption of banding	Functions to be fulfilled	Number of functions	
	Length (m)	20.00	1.03 m *
	Length scrap rate (3%)	0.60	0.15
	90° angle with plane change	3	0.20
	90° angle in the plane	4	0.00
	90° diversion in the plane	0	0.20
	Junction	4	0.10
	Termination of trunking	2	0.15
	Single apparatus mounting	3	0.05
	Double apparatus mounting	1	
* = 1.03 m of profiles taken into account to install 1 m of linear trunking function			

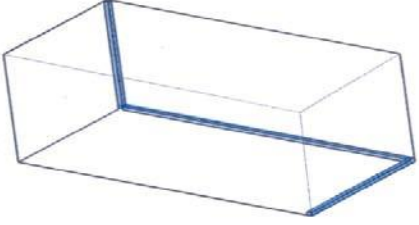
TYPICAL INSTALLATION NO.3 Distribution trunking systems	Basket of functions No.3 Distribution trunking systems		Total normalized to installed m
Room with a vertical drop (of 2.5 m) + 2 wall sections (8x8m)	Functions to be fulfilled	Number of functions	
	Length (m)	18.50	1.03 m *
	Length scrap rate (3%)	0.56	0.05
	90° angle with plane change	1	0.05
	90° angle in the plane	1	0.00
	90° diversion in the plane	0	0.38
	Junction	7	0.11
	Termination of trunking	2	0.00
	Single apparatus mounting	0	0.00
	Double apparatus mounting	0	0.00
* = 1.03 m of profiles taken into account to install 1 m of linear trunking function			

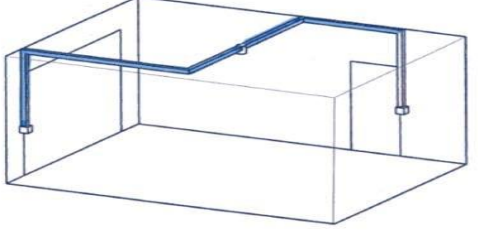
TYPICAL INSTALLATION N°4 Rigid conduit systems	Basket of functions No. 4 Rigid conduit systems		Total normalized to installed
home entry parking enclosure, (5x3 m) 15 m ² , with 2 vertical downfeeds to switches + 1 length & 1 width of profile to supply 1 light fitting	Functions to be fulfilled	Number of functions	
	Length (m)	11.00	1.03 m *
	Length scrap rate (3%)	0.33	0.00
	90° angle with plane change	0	0.36
	90° angle in the plane	4	0.00
	90° diversion in the plane	0	0.00
	Junction	0	0.00
	Termination of trunking	0	0.00
	Single apparatus mounting	0	0.00
	Double apparatus mounting	0	0.00
Wall mounting element	14.00	1.27	

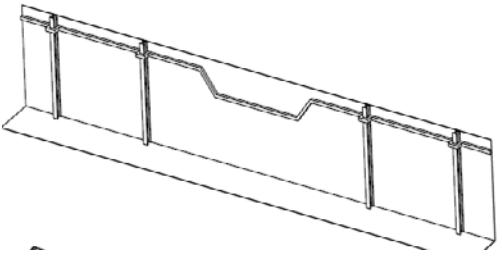
TYPICAL INSTALLATION NO.5 Trunking for distribution on cantilever brackets		Basket of functions No.5 Trunking for distribution on cantilever brackets		Total normalized to installed m
100m worksite with 4 obstacles (post contour) and 1 change of level		Functions to be fulfilled	Number of functions	
		Length (m)	100.00	1.03 m *
		Length scrap rate (3%)	3.00	
		90° angle with plane change	4	0.04
		90° angle in the plane	16	0.16
		Junction	33	0.33
		Earthing terminal (for a metal trunking and if imposed by national regulations)	10	0.10
		Cantilever bracket (including mounting elements to fix the length) - span 1.5 m	66	0.66

TYPICAL INSTALLATION NO.6 Floor trunking systems		Basket of functions No. 6 Floor trunking systems		Total normalized to installed m
<div style="border: 1px solid green; padding: 2px; display: inline-block;">Covered by 'Floor trunking conduit systems' family</div> <div style="border: 1px solid red; padding: 2px; display: inline-block; margin-left: 20px;">Not covered by 'Floor trunking conduit systems' family</div>		Functions to be fulfilled	Number of functions	
<p>The trunking is not accessible after installation</p> <p>Concrete cover</p> <p>Buried underground trunking (embedded in floor and not flush-mounted)</p> <p>Floor-mounted (and therefore non-embedded) trunking</p> <p>Concrete covering</p>		Length (m)	190	1.03 m *
<p>Flush-mounted trunking is accessible from above after installation</p> <p>Concrete cover</p> <p>Embedded trunking (floor- and flush-mounted)</p> <p>Leg-mounted (variable height) trunking before the covering is casted to be flush with the top of the trunking</p> <p>These trunking systems often consist of a cover removed after laying the covering and replaced by a functional cover</p>		Length scrap rate (3%)	5.7	
		90° angle with plane change	1	0.005
		90° angle in the plane	3	0.016
		90° diversion in the plane (T)	2	0.011
		Junction	63.3	0.333
		Termination of trunking	2	0.011
		Flush-mount box	62.3	0.327

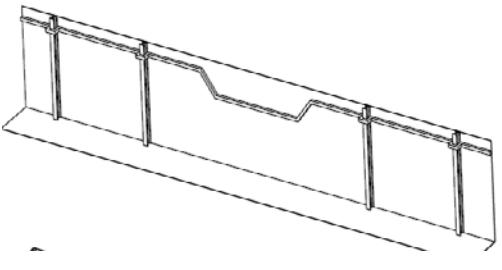
TYPICAL INSTALLATION NO.7	Basket of functions No.7		Total normalized
Cable tray systems	Cable tray systems		
100 m worksite with 4 obstacles (post contour) and 1 change of level	Functions to be fulfilled	Number of functions	1.03 m *
	Length (m)	100.00	
	Length scrap rate (3%)	3.00	
	90° angle with plane change	4	
	90° angle in the plane	16	
	Junction	33	
	Earthing terminal (for a metal trunking and if imposed by national regulations)	10	
	Bracket (including assembly elements to fix the length to the bracket)	66	
			0.10
		0.66	

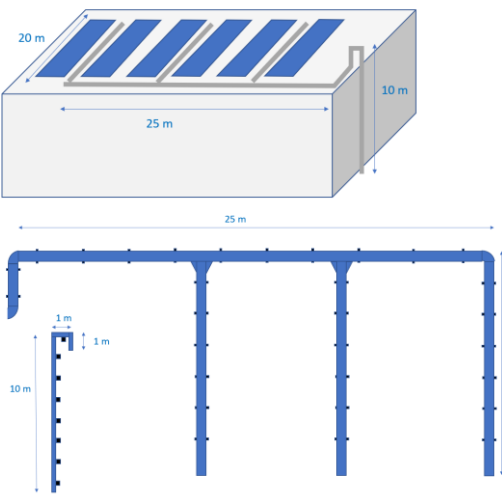
TYPICAL INSTALLATION NO.8	Basket of functions No.8		Total normalized to installed m
Cable tray systems for flat roof photovoltaic applications	Cable tray systems for flat roof photovoltaic applications		
100 m worksite with 4 obstacles (post contour) and 1 change of level	Functions to be fulfilled	Number of functions	1.03 m *
	Length with cover (in m)	100	
	Scrap rate on length with cover (3%)	3	
	90° angle in the plane with cover	3	
	90° angle with plane change with cover	3	
	90° diversion in the plane with cover	2	
	Junction	33	
	Termination of trunking	3	
	Frontage support (mounting elements to length included)	12	
	Flat roof support (mounting elements to length included)	100	
	Earthing terminal (for a metal trunking and if imposed by national regulations)	10	
			0.12
		1.00	
		0.03	
		0.03	
		0.03	

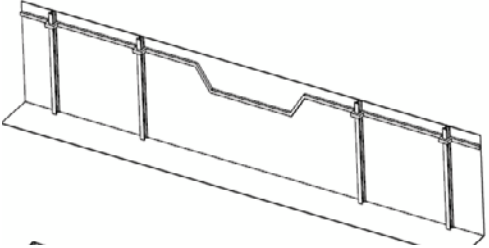
TYPICAL INSTALLATION NO.9 Cable ladder systems		Basket of functions No.9 Cable ladder systems		Total normalized to installed
100 m worksite with 4 obstacles (post contour) and 1 change of level		Functions to be fulfilled	Number of functions	
		Length (m)	100.00	1.03 m *
		Length scrap rate (3%)	3.00	
		90° angle with plane change	4	0.04
		90° angle in the plane	16	0.16
		Junction	33	0.33
		Earthing terminal (for a metal trunking and if imposed by national regulations)	10	0.10
		Bracket (including assembly elements to fix the length to the bracket)	50	0.50

6.3. Appendix 3: Glossary

A	Ampere
LCA	Life Cycle Assessment
LV	Low Voltage
°C	Celsius Degrees
SWL	Safe Working Load
RSL	Reference Service Life
HETT	Home Entry Technical Trunking
IEC	International Electrotechnical Commission
IGNES	Industrie du Génie Numérique, Energétique et Sécuritaire
P	Power
PCR	Product Category Rules
PEP	Product Environmental Profile
PSR	Product Specific Rules
FU	Functional Unit
USB	Universal Serial Bus
V	Volt
W	Watt
Z	Impedance

6.4. Appendix 4: Definitions

No specific definitions for PSR 0003.

6.5. Appendix 5: References

Reference standards:

- Installation cable trunking systems (including mini-trunking and skirting): EN 50085-1 and EN 50085-2-1 standards and future EN IEC 61084-1 and EN IEC 61084-2-1 standards
- Distribution cable trunking systems (including trunking on consoles): EN 50085-1 and EN 50085-2-1 standards and future EN IEC 61084-1 and EN IEC 61084-2-1 standards EN 50085 standard
- Cable ducting systems: EN 50085-1 and EN 50085-2-1 standards and future EN IEC 61084-1 and EN IEC 61084-2-1 standards EN 50085 standard
- Conduit systems: EN 61386 standard
- Cable tray systems: EN 61537 standard
- Cable ladder systems: EN 61537 standard
- Home entry technical trunking: EN 50085-1 and EN 50085-2-1 standards and future EN IEC 61084-1 and EN IEC 61084-2-1 standards EN 50085 standard
- Floor boxes: EN 60670-23 standard + EN 50085-1 and EN 50085-2-2 standards and future EN IEC 61084-1 and EN IEC 61084-2-2 standards, EN50085-2-2 standard
- Service poles and service posts: EN 50085-1 and EN 50085-2-4 standards and future EN IEC 61084-1 and EN IEC 61084-2-4 standards, EN 50085-2-4 standard
- Slotted cable trunking systems for cabinets: EN 50085-1 and EN 50085-2-3 standards and future EN IEC 61084-1 and EN IEC 61084-2-3 standards, EN 50085-2-3 standard
- Articulated and flexible cable guide systems: EN 62-549 standard
- Electrical installation mounting systems: EN 62275 standard + IEC 61914 + IEC 62275

Packaging end-of-life data references:

- Ademe - Household Packaging Report 2020 data p28 - <https://bibliothèque.ademe.fr/dechets-economie-circulaire/28-dechets-chiffres-cles-edition-2020-9791029712135.html#:~:text=Cette%20nouvelle%20%C3%A9dition%202020%20des,de%20graphes%2C%20cartes%20et%20tableaux.>
- Ademe - Ademe - Household Waste Report 2020 key figures p15 - <https://bibliothèque.ademe.fr/dechets-economie-circulaire/28-dechets-chiffres-cles-edition-2020-9791029712135.html#:~:text=Cette%20nouvelle%20%C3%A9dition%202020%20des,de%20graphes%2C%20cartes%20et%20tableaux.>
- Citeo - Report on key household waste sorting and recycling figures in 2020 - <https://www.citeo.com/le-mag/les-chiffres-du-recyclage-en-france#materiaux>

6.6. Appendix 6: Declaration of conformity



Solutions innovantes pour l'environnement

PROGRAMME PEP Ecopassport

Attestation de revue-critique des règles spécifiques aux Solutions de cheminement de câbles

Document revu : PSR, Règles spécifiques aux Solutions de cheminement de câbles

Version et date : PSR-0003-ed2.0-FR-2023 du 17 avril 2023

Établi par : l'Industrie du Génie Numérique, Énergétique et Sécuritaire

L'Industrie du Génie Numérique, Énergétique et Sécuritaire (IGNES) a demandé à Solinnen, en tant que bureau d'études spécialisé en Analyse du Cycle de Vie (ACV), la revue critique des règles spécifiques aux Solutions de cheminement de câbles.

Référentiels

L'objectif de la revue critique est de vérifier la conformité de ce document avec les référentiels suivants :

- le Programme PEP ecopassport, il s'agit du document intitulé : « PCR Règles de définition des catégories de produits relatives aux équipements électriques, électroniques et de génie climatique », dont la référence est : « PCR-ed4-FR-2021 09 06 » disponible à l'adresse : <https://register.pep-ecopassport.org/documents>;
- la norme NF EN ISO 14025:2010;
- les normes NF EN ISO 14040:2006 & NF EN ISO 14044:2006.

Conclusion

Le document revu ne comporte pas de non-conformité par rapport aux référentiels. Par conséquent, ce document – PSR, Règles spécifiques aux Solutions de cheminement de câbles – est conforme aux exigences des référentiels.

Le 17/04/2023

Philippe Osset
Président de Solinnen

Revue critique des règles spécifiques sectorielles

SOL 22-145.1
<https://www.solinnen.com/>

17 avril 2023

Solinnen, société par action simplifiée au capital de 79 721,00 Euros
RCS : Paris 523 138 493 – SIREN : 523 138 493 – TVA : FR 14 523 138 493 – APE : 7490B
Siège social : 25, rue des Mathurins- 75008 Paris – Tél : 01 83 64 53 86 – Email : contact@solinnen.com
Déclaration d'activité comme prestataire de formation enregistrée sous le numéro 11 75 47228 75 auprès du préfet de région d'Île-de-France et référençable dans Datadock. Cet enregistrement ne vaut pas agrément de l'État